

UNIVERSAL INK REFILL KIT GUIDE

Content:

- 3x Ink Kits
- 1x Nozzle cleaner kit
- 1x Drill
- 1x Injector tool
- 4x Blunt injection needle for the filling cartridges
- 1x Bradawl
- 1x A and B transparent sealers
- 4x Black round sealers
- 1x Drill tool
- 3x Steel ball
- 4x Rubber plug
- 1x Transparent gloves
- 1x Tissue



Hand/ Spike Instructions

1. Push the injector tool into the bottom of the injector to make a hole.
2. Turn the injector tool 90deg to the right.
3. Turn the flap to the left, to uncover the injection needle.
4. Attach the injection needle and secure it with a clockwise rotation.
5. Press the injector tool to release the ink.

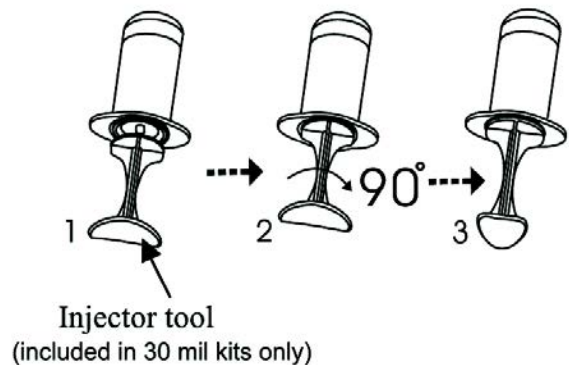

Universal Refill Instructions

Please read the instructions below carefully before using the universal refill kits:

1. Find the brand of your printer in the list above and then select the exact model of your printer from one of those pages.
2. Remove the cartridge from the printer and avoid touching metallic parts.
3. Carefully clean the print head to remove dried ink. If a cartridge has been left empty or stored for a long time, the print head may become clogged.
4. Change your cartridge after five refills, as print heads wear with use.
5. Refill empty cartridges immediately to ensure best print quality.
6. If the cartridge does not print well after print head cleaning, leave the cartridge in the printer for 3 to 5 hours, and then perform nozzle testing as recommended by your printer model's instructions. If the printer still does not work normally, this indicates that the print head has been dried-out or damaged beyond repair.
7. When filling color indicators to ensure that cartridges are refilled with the correct color.
8. For the cartridge with chip, before reinstalling it into the printer, please reset the chip with chip resetter or replace it with a new one.

Cartridge & Print Head Cleaner Instructions

If a cartridge has been unused, left empty or stored for a long period of time, the nozzles may become blocked with dried ink residue. Nozzles and print heads are extremely delicate and sensitive and can be damaged easily if any material other than a specifically formulated solvent is used to clean them.

There are several ways to utilize the cartridge & print head cleaner:

- Fill the syringe with 2ml of Cartridge & Print Head Cleaner and squirt the fluid onto the print head over the sink. Do not touch the print head with the needle point. The dried ink will become soluble and wash away. Let it air dry and reinsert into the printer.
- Pour 1/2 of the Cartridge & Print Head Cleaner into a disposable container and let the cartridge soak. NOTE WARNING BELOW AND KEEP OUT OF REACH OF CHILDREN AT ALL TIMES. Allow to air dry and reinstall into the printer and run a cleaning cycle as per the printer instructions. Be sure to dispose of container properly after use.
- Apply a small amount of Cartridge & Print Head Cleaner to a paper towel or soft tissue. Next, sit the print head directly where the Cartridge & Print Head Cleaner was applied. Allow the cartridge to sit for 2 minutes and then press it dry with a clean tissue. To avoid damaging the print head, do not rub the print head on the paper towel in any manner.

WARNING!

HARMFUL IF SWALLOWED.

Keep out of reach of children.

Do NOT induce vomiting if swallowed. Seek medical attention immediately. Contains diethylene glycol.

SKIN AND EYE IRRITANT.

If ink comes into contact with eyes, Wash with water for 15 minutes.

CANON BC-01, BC-02, BX-2, BC-20, BC-05, IH-205, IH-055

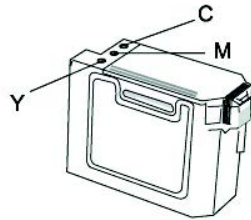

(BC-05,06,IH-055)

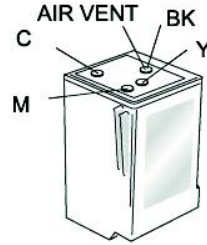

(BC-22,22e)

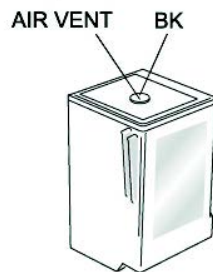

(BC-20,23,IH-205)



(BC-01,02,BX-2)

1. Put the cartridge on tissue or other absorbent material in case of excess ink.
2. Insert the drill tool into the air vent of plug, turn and remove the plug to expose the filling hole. (The plug of the BC-01, 02, 05, 06 and IH-055BX-2 is on the side of the cartridge. The plug of the IH-205 BC-20, 23, 22 and 22e is on the top of the cartridge.)
3. Assemble the syringe and needle. Please slowly insert the needle deeply into the drilled filling hole, without the needle touching the bottom of the cartridge. Continue slowly and carefully push the plunger in to completely fill the ink tank, and then remove the syringe and needle.
4. Clean the ink on the surface of the filling hole with a tissue.
5. Reload the cartridge into the printer and run "head cleaning" utility 2-3 times before printing or nozzle testing.

CANON BC-03, BX-03

1. Put the cartridge on tissue or other absorbent material in case of excess ink.
2. Insert the drill tool into the air vent of plug, turn and remove the plug to expose the filling hole. (The plug of the BC-01, 02, 05, 06 and IH-055BX-2 is on the side of the cartridge. The plug of the IH-205 BC-20, 23, 22 and 22e is on the top of the cartridge.)
3. Assemble the syringe and needle. Please slowly insert the needle deeply into the drilled filling hole, without the needle touching the bottom of the cartridge. Continue slowly and carefully push the plunger in to completely fill the ink tank, and then remove the syringe and needle.
4. Clean the ink on the surface of the filling hole with a tissue.
5. Reload the cartridge into the printer and run "head cleaning" utility 2-3 times before printing or nozzle testing.

FILLING HOLE

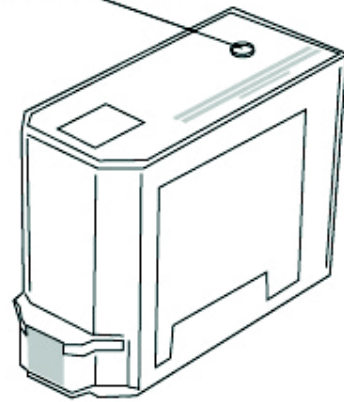

CANON BCI-3, BCI-6M, PGI-5BK, CLI-8, PGI-520BK, CLI-521, PGI- 525BK, CLI-526

1. Seal the outlet with sealing tape and place the cartridge on paper towel or other absorbent material in case of excess ink. Make sure the outlet is facing down.
2. Use the drill to make a filling hole on the cover located as shown in the figure above.
3. Assemble the syringe and needle. Please insert the needle slowly deep into the drilled filling hole, without the needle touching the bottom of the cartridge. Continue slowly and carefully push the plunger in to completely fill the ink tank, and then remove the syringe and needle.
4. Seal the filling hole with the rubber plug.
5. Clean any ink that may have leaked from the outlet with a tissue.
6. Reload the cartridge into the printer and run "head cleaning" utility 2-3 times before printing or nozzle testing.

FILLING HOLE PLACE

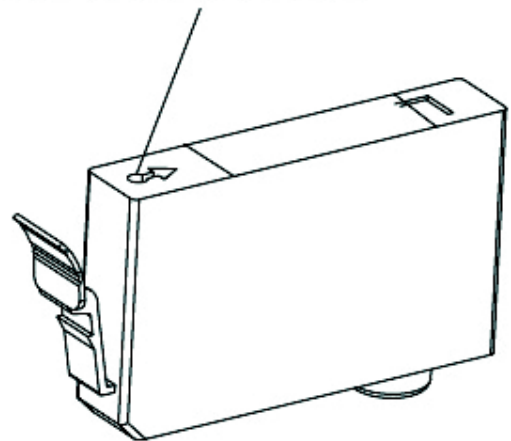

CANON BCI-10BK, BCI-11BK, BCI-11C, BCI-15BK, BCI-15C, BCI-16C, PGI-35, CLI-36

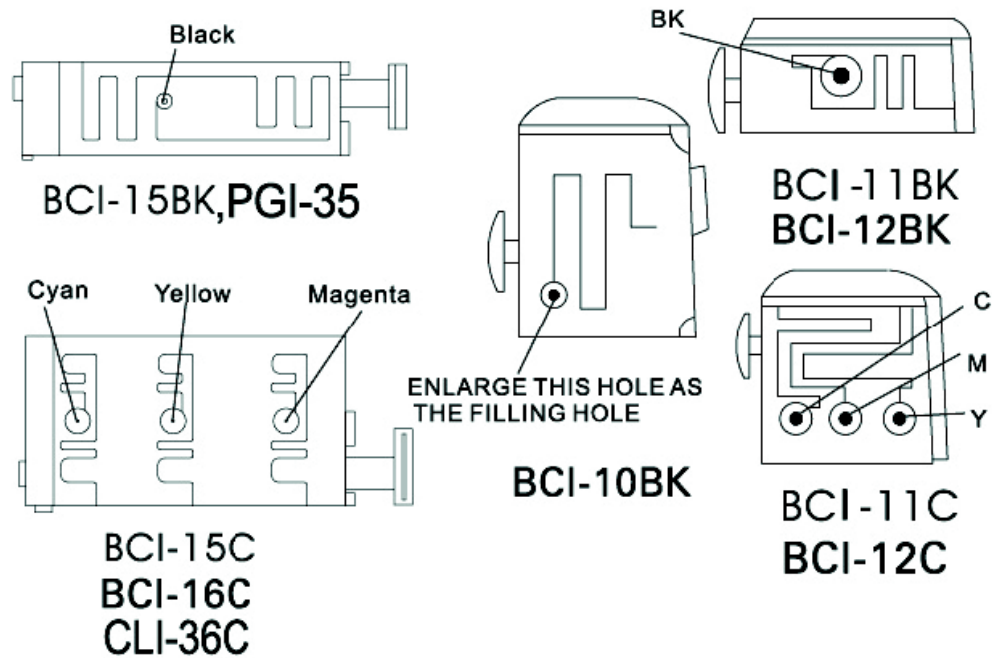

1. Put the cartridge on paper towel or other absorbent material in case of excess ink.
2. Remove the cartridge label to expose the filling holes (see figure above). Enlarge the filling hole with the drill.
3. Assemble the syringe and needle. Please slowly insert the needle deeply into the drilled filling hole, without the needle touching the bottom of the cartridge. Continue slowly and carefully push the plunger in to completely fill the ink tank, and then remove the syringe and needle.
4. Clean the ink on the surface of the filling hole with a tissue. Re load the cartridge into the printer. Run the "head cleaning" utility 2-3 times before printing or nozzle testing.

LEXMARK 1340HC, 16, 17, 50, 70, 75, 82
XEROX 8R7881, 8R7882
DELL T0529, 7Y743, T0601
SAMSUNG M10

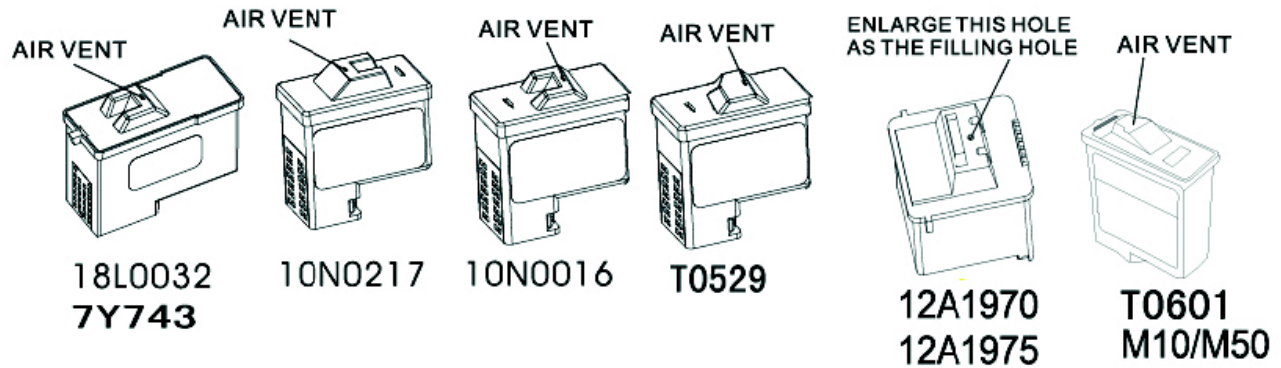

1. Put the cartridge on paper towel or other absorbent material in case of excess ink.
2. Enlarge the filling hole with a drill as indicated in the figure above.
3. Assemble the syringe and needle. Please slowly insert the needle deep into the drilled filling hole, without the needle touching the bottom of the cartridge. Continue slowly and carefully push the plunger in to completely fill the ink tank, and then remove the syringe and needle.
4. Clean the ink on the surface of the nozzle with a tissue and reload the cartridge into the printer. Run the "head cleaning" utility 2-3 times before printing or nozzle testing.

LEXMARK 13619HC, 20, 25, 26, 27, 60, 80, 83, 90 XEROX 8R7880, 8R12591 DELL T0530, T0602, 7Y745

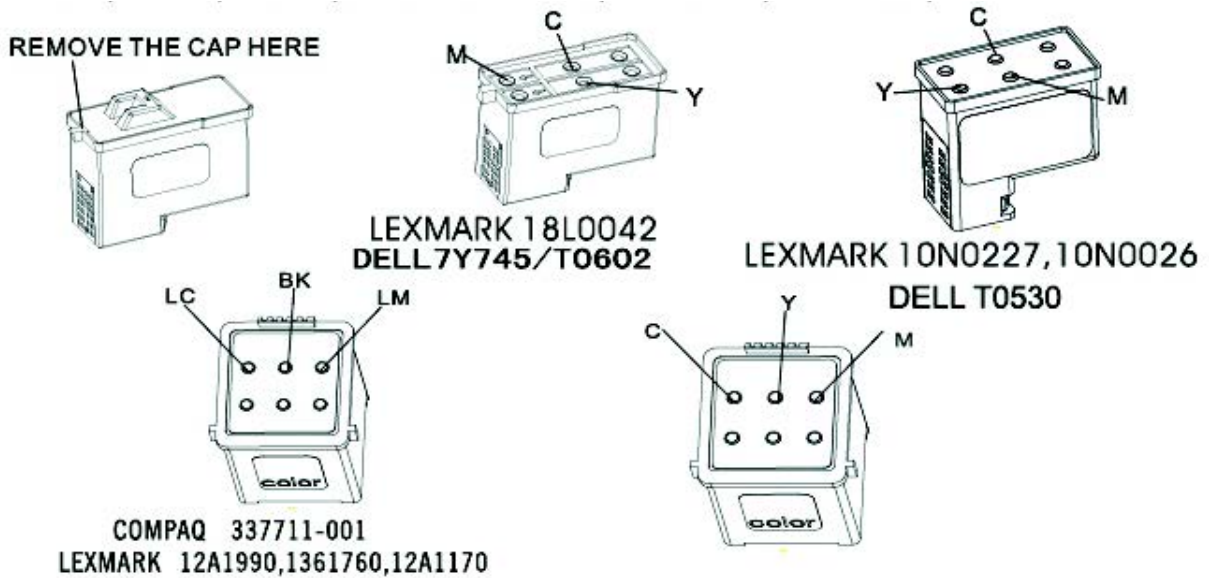

1. Put the cartridge on paper towel or other absorbent material in case of excess ink.
2. Cut the seal carefully and remove the cap of the cartridge as shown in the figure above. Place the cartridge on the paper towel so the nozzle is facing down.
3. Assemble the syringe and needle. Please slowly insert the needle deeply into the drilled hole, without the needle touching the bottom of the cartridge. Continue slowly and carefully push the plunger in to completely fill the ink tank, and then remove the syringe and needle.
4. After refilling, seal the cap again that was removed in Step 2 with permanent tape.
5. Clean the ink on the surface of the nozzle with a tissue and reload the cartridge into the printer. Run the "head cleaning" utility 2-3 times before printing or nuzzle testing.

LEXMARK 31A, 32A, 33A, 34A, 35A DELL J5567, J5566, M4640, M4646, J4844

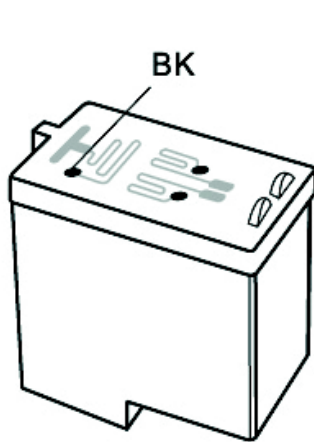

18C0032、18C0034
DELL J5566、M4640

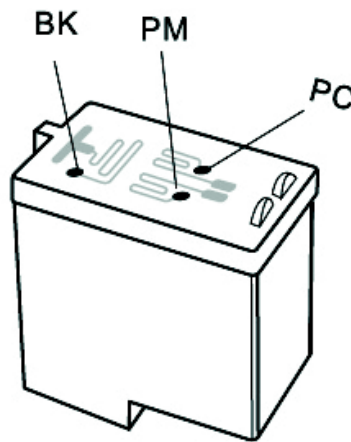

18C0031
DELL J4844

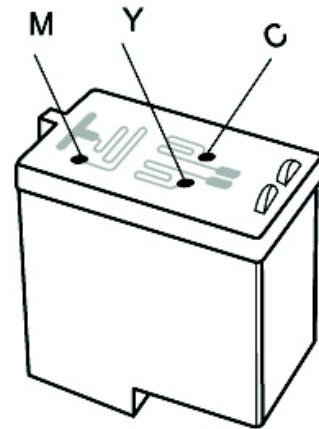

18C0033、18C0035
DELL J5567、M4646

1. Put the cartridge on paper towel or other absorbent material in case of excess ink. Make sure the nozzle is facing down.
2. Carefully remove the label on the cartridge and put aside the label for re-use. Locate the filling hole (ink) for the color you want to refill per the figure above.
3. Assemble the syringe and needle. Please slowly insert the needle deeply into the drilled hole, without the needle touching the bottom of the cartridge. Continue slowly and carefully push the plunger in to completely fill the ink tank, and then remove the syringe and needle.
4. Repeat step 3 for each color you wish to refill.
5. Clean the ink on the surface of the filling hole with a tissue and carefully reapply the label.
6. Reload the cartridge into the printer and run "head cleaning" utility 2-3 times before printing or nozzle testing.

HP 45, HP 40, HP 15, HP 44

1. Put the cartridge on paper towel or other absorbent material in case of excess ink.
2. Open the black spot on the bottom of the cartridge. Use the thinner end of the bradawl to press the steel ball into the cartridge and expose the filling hole.
3. Assemble the syringe and needle. Please slowly insert the needle deeply into the drilled hole, without the needle touching the bottom of the cartridge. Continue slowly and carefully push the plunger in to completely fill the ink tank, and then remove the syringe and needle.
4. Use the larger end of the bradawl to plug the filling hole with another steel ball. Clean the filling hole and the steel ball with a tissue before applying the leak proof tape over the filling hole.
5. Press the sides of the cartridge slightly, 2-3 times, to make sure the outlet is filled with ink.
6. Clean the nozzle with a tissue and reload the cartridge into the printer. Run the "head cleaning" utility 2-3 times before printing or nozzle testing.

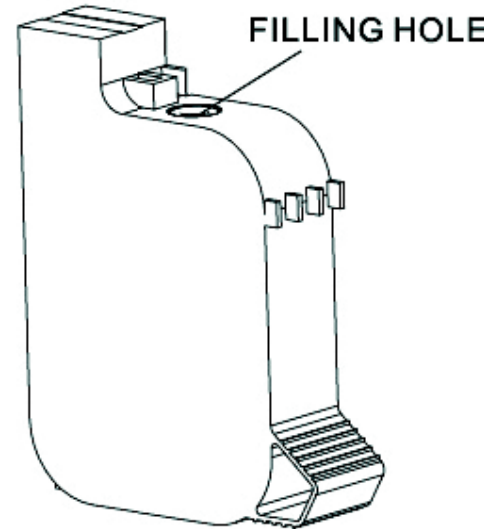

HP 26, HP 29, HP 20

1. Put the cartridge on paper towel or other absorbent material in case of excess ink. Make sure the outlet is facing down.
2. Use the drill to make a filling hole located as shown in the figure above.
3. Assemble the syringe and needle. Please slowly insert the needle deep into the drilled hole, without the needle touching the bottom of the cartridge. Continue slowly and carefully push the plunger in to completely fill the ink tank, and then remove the syringe and needle.
4. Seal the filling hole with the rubber plug.
5. Leave the cartridge on the paper towel until the ink does not leak from the nozzle any longer. Make sure the nozzle is facing down.
6. Clean the cartridge with a tissue. Reload the cartridge into the printer and run "head cleaning" utility 2-3 times before printing or nozzle testing.

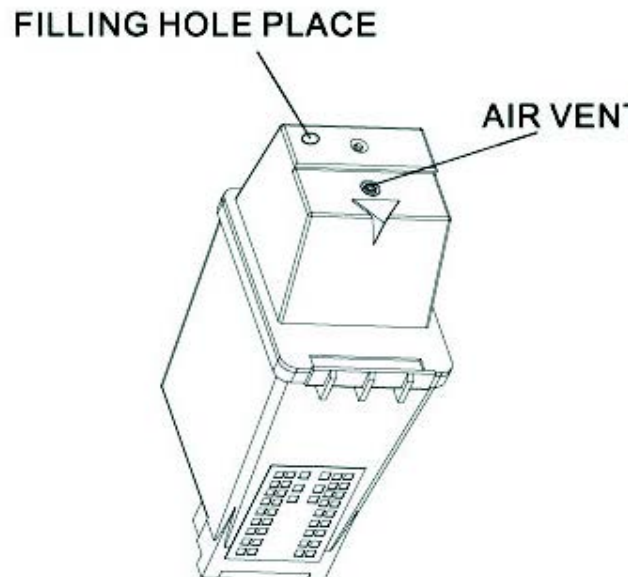

HP 25, 49

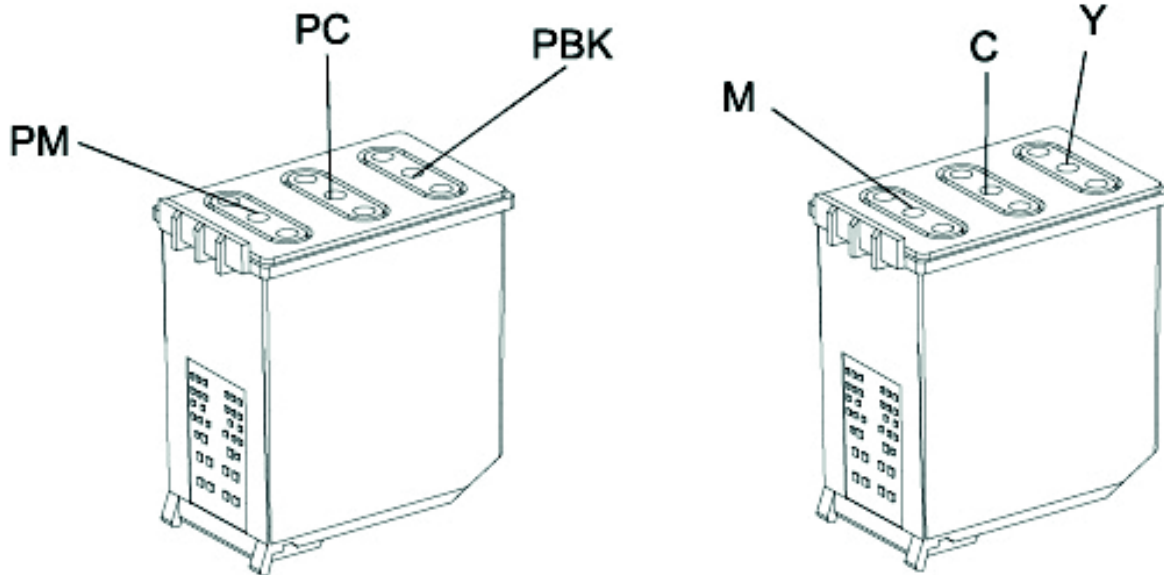

1. Put the cartridge on paper towel or other absorbent material in case of excess ink.
2. Cut the cap off the cartridge along the seal and set aside for reapplying. Put the cartridge on the paper towel and make sure the outlet is facing down.
3. Assemble the syringe and needle. Please slowly insert the needle deep into the drilled hole, without the needle touching the bottom of the cartridge. Continue slowly and carefully push the plunger in to completely fill the ink tank, and then remove the syringe and needle.
4. Put the cap back into original place and press tightly. Use the permanent tape to stabilize.
5. Clean the ink on the surface of the nozzle with tissue. Reload the cartridge into the printer and run "head cleaning" utility 2-3 times before printing or nozzle testing.

HP 27, 28, 56, 57, 58

CANON PG-40, PG-50, CL-41, CL-51

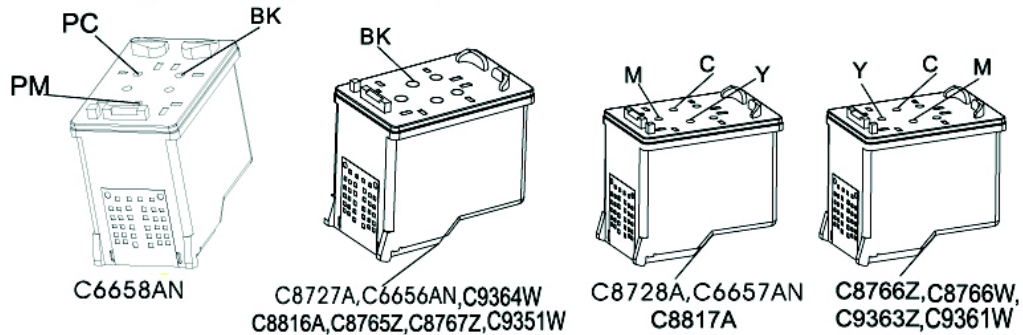

CANON PG-40Black, PG-50Black, CL-41Color, CL-51Color, CL-52Photo Color
 PG-240Black, PG-210Black, CL-241Color, CL-211Color

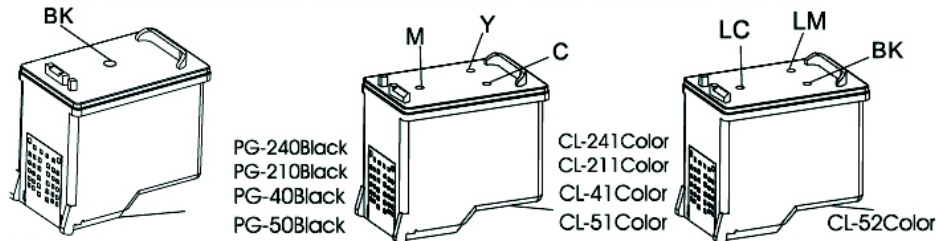

1. Put the cartridge on paper towel or other absorbent material in case of excess ink. Make sure the nozzle is facing down.
2. Carefully remove the label on the cartridge and put aside the label for re-use. Locate the filling hole (ink) for the color you want to refill per the figure above. Make screwdriver aim at ink-let and circumgyrate the screwdriver to enlarge the aperture and the needle can be insert.
3. Assemble the syringe and needle. Please slowly insert the needle deep into the drilled hole, without the needle touching the bottom of the cartridge. Continue slowly and carefully push the plunger in to completely fill the ink tank, and then remove the syringe and needle.
4. Repeat step 3 for each color you wish to refill.
5. Clean the ink on the surface of the filling hole with tissue and carefully reapply the label.
6. Reload the cartridge into the printer and run "head cleaning" utility 2-3 times before printing or nozzle testing.

HP 41, 23, 78A, 780 , 17

1. Put the cartridge on paper towel or other absorbent material in case of excess ink.
2. It is especially important to only refill the colors that show they are empty when you run a nozzle test or printing test.
3. The filling holes are located on top of the cartridge and are sealed with three small-vented plugs. Push these plugs into the cartridge using a ballpoint pen.
4. Assemble the syringe and needle. Please slowly insert the needle deeply into the drilled hole, without the needle touching the bottom of the cartridge. Continue slowly and carefully push the plunger in to completely fill the ink tank, and then remove the syringe and needle.
5. Hold and shake the cartridge up and down 2-3 times to fill the outlet with ink. Please make sure the filling hole is facing up.
6. Repeat steps 4-5 for each color that needs to be refilled.
7. Clean the ink on the surface of the filling hole with a tissue and carefully re-apply the label. Reload the cartridge into the printer and run "head cleaning" utility 2-3 times before printing or nozzle testing.



C1823A,C6625AN
C6578AN,C6578DN,51641A

HP 10, 11, 82, 84, 85

1. According to the printer operation instructions, take out the corresponding cartridge.
2. Gash the plastic label with a knife, to separate the chip cover from the cartridge body.
3. Take out the plastic stopper from the filling hole with an acute needle, then seal the filling hole with an additional rubber lid.
4. Take out the syringe, remove the sealing cap, fit on the needle, and take off its sheath, then insert the needle vertically into the filling hole, carefully press the syringe plunger for filling (for high capacity, please inject about 40ml and for standard capacity about 20ml)
5. Fit the chip cover which is separated at step 2 back to the cartridge, then reload the cartridge into the printer and run "head cleaning" about 2-3 times before trial printing or nozzle testing.

